



# LUMINA HIGH DUTY SOLAR STREET LANTERN

DAYLIGHT / 6500K



### MODERN AND INNOVATIVE

Modern Design with Round Edge Shape.



### ADJUSTABLE ANGLE

180° for Solar Panel and 120° Lamp Adjustable Angle for Adjusting the Angle More Precisely and Meet Your Charging Requirements.



### AERODYNAMIC SHAPE

Tested To Withstand Strong Wind.



### LARGE STORAGE BATTERY CAPACITY

Low Light Fast Charging.



### CORROSION AND RUSTING RESISTANCE

Professional Outdoor Painting, Stainless Steel Components, Anti-Corrosion And Anti-Rusting in Harsh Environment.



### UNIVERSAL INTERFACE

Universal Forward Discharge and Reverse Charge Efficient and Safe.

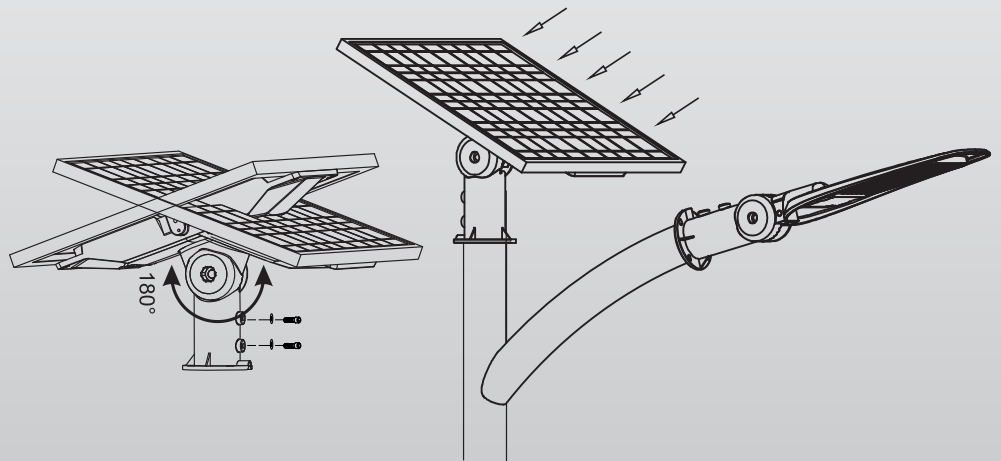
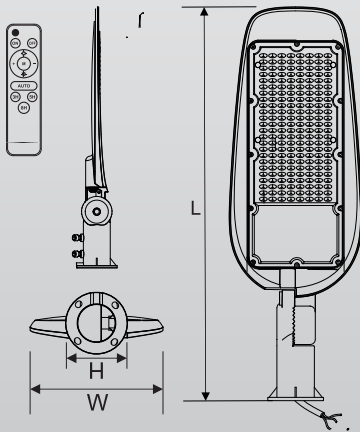

## Physical Dimensions

### Lamp Body

Model	Power (Watt)	Lamp Type	CCT	Lumen	CRI	IP Rating	Working Temperature
MLX-SSL01-200DL	200W	2835 Lumileds	6500K	3000LM	>70	IP65	-20°C ~ +50°C
MLX-SSL01-300DL	300W			5000LM			

### Battery

### Solar Panel

### Dimensions

Model	Capacity	Power	Material	Lamp	Solar Panel
MLX-SSL01-200DL	3.2V 60Ah	6V 60W	Polysilicon	468.5 x 151.2 x 88mm	600 x 670 x 25mm
MLX-SSL01-300DL	12V 30Ah	18V 100W		564 x 189 x 88mm	600 x 1300 x 25mm



Light Distribution Curve

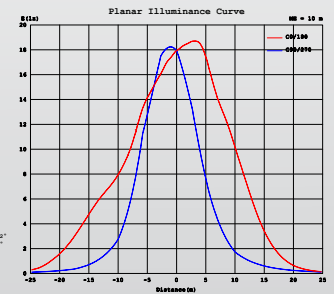
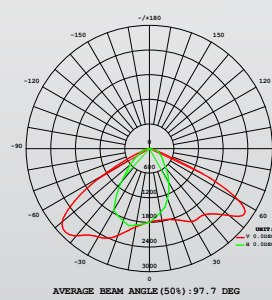
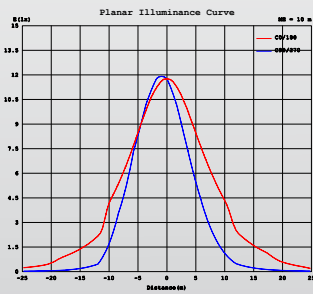
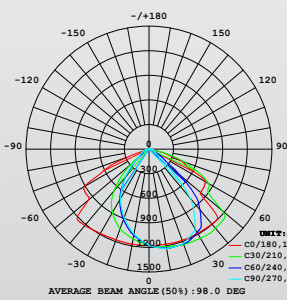

- ISO  
9001:2015
- CE
- CB
- RoHS
- Ra  
>70
- IP65
- Color Temp  
6500K