



## ROWENA LED SOLAR STREET LANTERN

DAYLIGHT / 6500K



### MODERN AND INNOVATIVE

Modern Design with Round Edge Shape.



### ADJUSTABLE ANGLE

120° Adjustable Angle for Adjusting the Angle More Precisely.



### AERODYNAMIC SHAPE

Tested To Withstand Strong Wind.



### EXCELLENT HEAT DISSIPATION

Air Convection Design To Release Heat Inside The Lamp for Ensuring Excellent Heat Dissipation.



### CORROSION AND RUSTING RESISTANCE

Professional Outdoor Painting, Stainless Steel Components, Anti-Corrosion And Anti-Rusting in Harsh Environment.

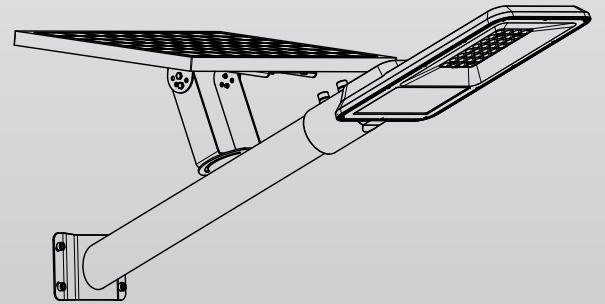
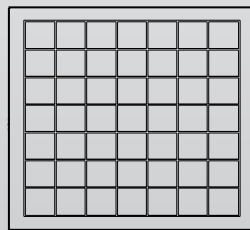
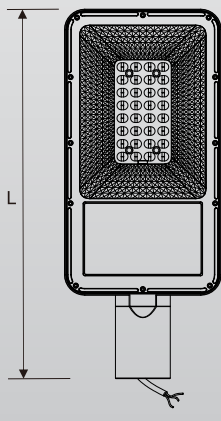
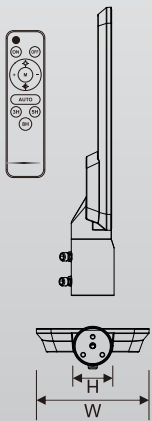

### Physical Dimensions

#### Lamp Body

Model	Power (Watt)	Lamp Type	CCT	Lumen	CRI	IP Rating	Working Temperature
MLX-SSL01-100DL	100W	Bridgelux SMD5050	6500K	2600LM	>80	IP65	-20°C ~ +50°C
MLX-SSL01-150DL	150W	Bridgelux SMD5050	6500K	3900LM	>80	IP65	-20°C ~ +50°C

#### Battery

Capacity	Material
3000mAh	LiFePO4 Battery
4000mAh	

#### Solar Panel

Power	Material
30W	Polycrystalline
40W	

	Dimensions (mm)	Solar Panel
MLX-SSL01-100DL	545 x 200 x 97mm	620 x 350 x 25mm
MLX-SSL01-150DL	579 x 222 x 97mm	590 x 610 x 25mm



### Light Distribution Curve

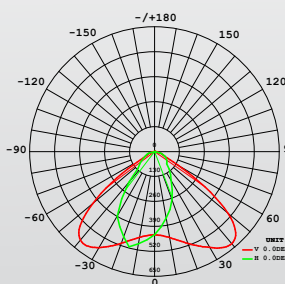

AVERAGE BEAM ANGLE (50%) : 83.4 DEG

100W- Luminous Intensity Distribution

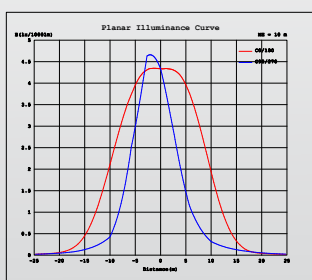

100W Planar Illuminance Curve

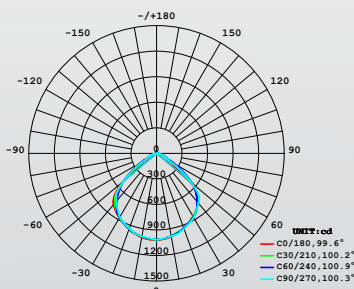

AVERAGE BEAM ANGLE (50%) : 100.2 DEG

150W- Luminous Intensity Distribution

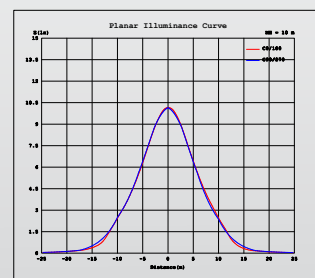

150W Planar Illuminance Curve

